





# BUMPA INCLINED ELEVATOR

## 80kg Inclined Elevator Goods Lift

### KEY SPECIFICATIONS

	<b>Max Working Height</b>	7m
	<b>Weight</b>	105kg
	<b>Stowed Height</b>	0.85m
	<b>Stowed Width</b>	0.6m
	<b>Stowed Length</b>	4.3m

### BUMPA INCLINED ELEVATOR HOIST

Ever popular with roofers and builders, inclined elevator hoists are angled goods lifts. With a max payload of 80kg, the Bumpa hoist can lift a range of materials such as bricks and roof tiles in payloads up to 20kg continuously at four payloads at a time. Because the payload is being lifted continuously the Bumpa can out-perform larger hoists.

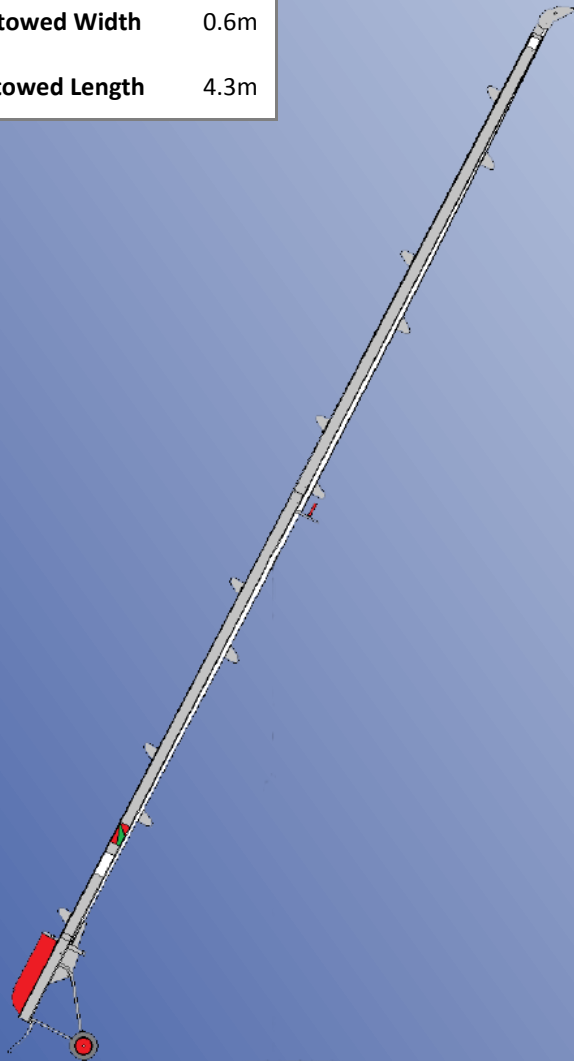

*Rapid*  
**PLATFORMS**

Evolving with Access  
since 1982



**HIRE | SALES | SERVICE | TRAINING**

**Call: 01279 501501**

**Email: info@rapidplatforms.co.uk**

**Visit: www.rapidplatforms.co.uk**

Rapid Platforms Ltd, London Road, Spellbrook, Bishop's Stortford, Herts, CM23 4AU

# BUMPA INCLINED ELEVATOR

## 80kg Inclined Ladder Elevator Goods Lift

The carrying capacity of the hoist is 80kg Maximum and each individual carrier has a payload of 20kg Maximum

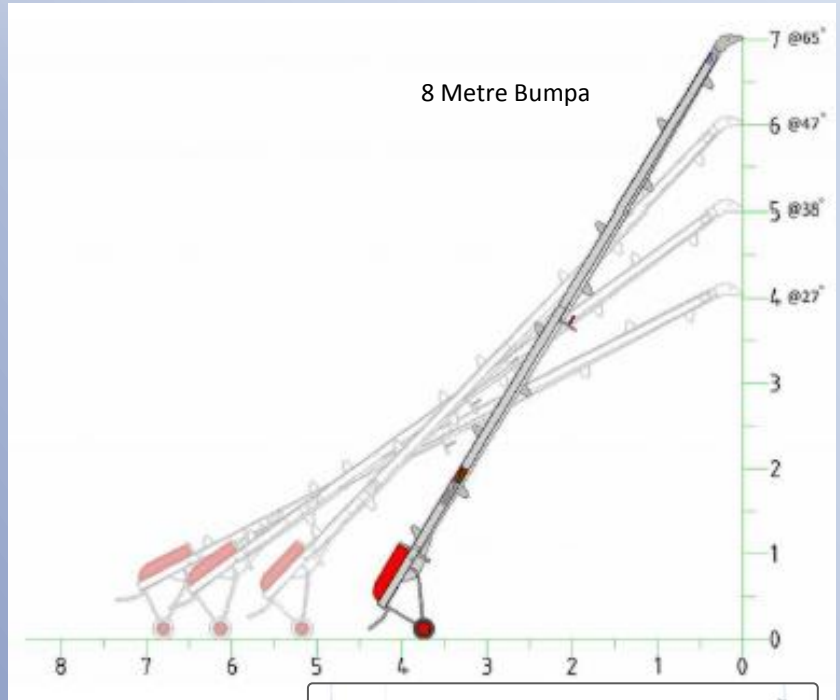

**ERECT & STRIKE SERVICE**

**HOIST SERVICE & THOROUGH EXAMINATIONS**

**SCHEDULE 1 DOCUMENT WITH HIRE HOISTS**

**NEW AND USED HOIST SALES**

### TECHNICAL DATA

Max Payload	80kg
Max Carrier Load	20kg
Max Angle	65°
Min Angle	27°
Belt Speed	20m/min
Electric Motor	0.75kw
Noise Level	>75dB
Power Supply	Honda GX120

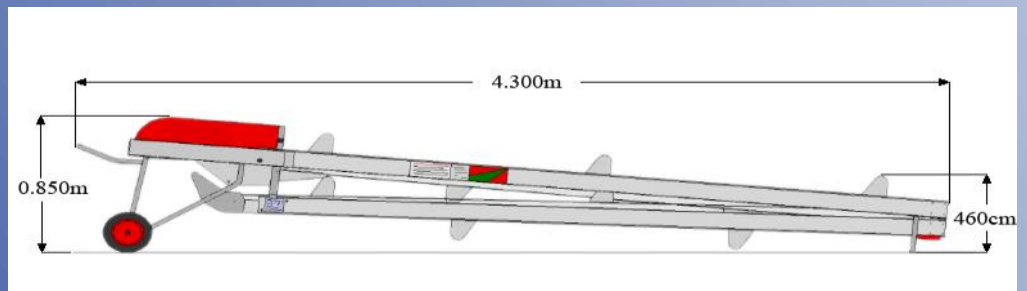

**HIRE | SALES | SERVICE | TRAINING**

**Call: 01279 501501**

**Email: info@rapidplatforms.co.uk**

**Visit: www.rapidplatforms.co.uk**

**Rapid Platforms Ltd, London Road, Spellbrook, Bishop's Stortford, Herts, CM23 4AU**